



KASTR CU-T 77



## Revolution in clamping

KASTR CU - T 77

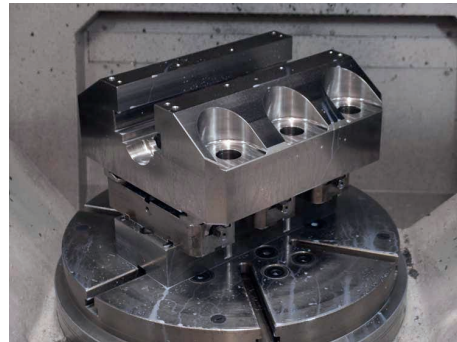
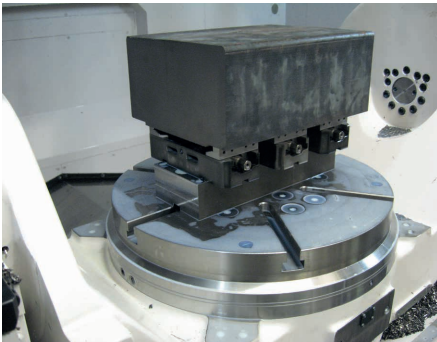

Clamping force 4 t  
Torque wrench 200 Nm

Manufactured on **1 clamping** by 3 mm.  
**Body of RSVS - HT**

# Centric clamp CU-T 77

## Little, but clever!

### Without pre-marking

KASTR CU - T 77 is a special type of centric clamp with hard chucks. Using most of competitor's clamp, it is necessary to first pre-mark the tooth prints with hydraulic devices; this eliminates possible clamping forces. Our clamp CU-T 77 needs no pre-marking, you will simply clamp, machine - and the clamp holds perfectly.

### Unlimited possibilities of setting

The clamp can be simply set into a standart precise cross groove, without the clamp body overrunning the jaw width. As a result of that, more clamps can be set for the clamping of larger workpieces according to any configurations and various arrangements.

### Durability

Together with a long lifetime of the clamps we also guarantee a long lifetime of the clamping jaws. At the clamping of aluminium and copper alloys the lifetime is almost unlimited. At the steel clamping of 20HRC initial hardness the lifetime can be supposed to be in the orders of tens of thousands cycles.

### Strength

The clamp is designed for a primary clamping on 3 mm without any limitation by the cutting conditions and the machine possibilities. By the geometry optimization, seeking for new materials, and by the heat treatment we have moved the workpiece holding possibilities to a new dimension where the clamped semi-product mass - at the clamping on 3 mm - exceeds the clamp mass twenty times absolutely safely at any inclination and in any roughing process.

Main dimension	mm
Height	70
Width	77
Length	210

## Contacts

**Miloslav Kaderka - Kastr**  
Rozhraní 172  
569 03 ROZHRANÍ  
CZECH REPUBLIC

tel +420 461 523 457  
email: [jkaderka@kastr.cz](mailto:jkaderka@kastr.cz)



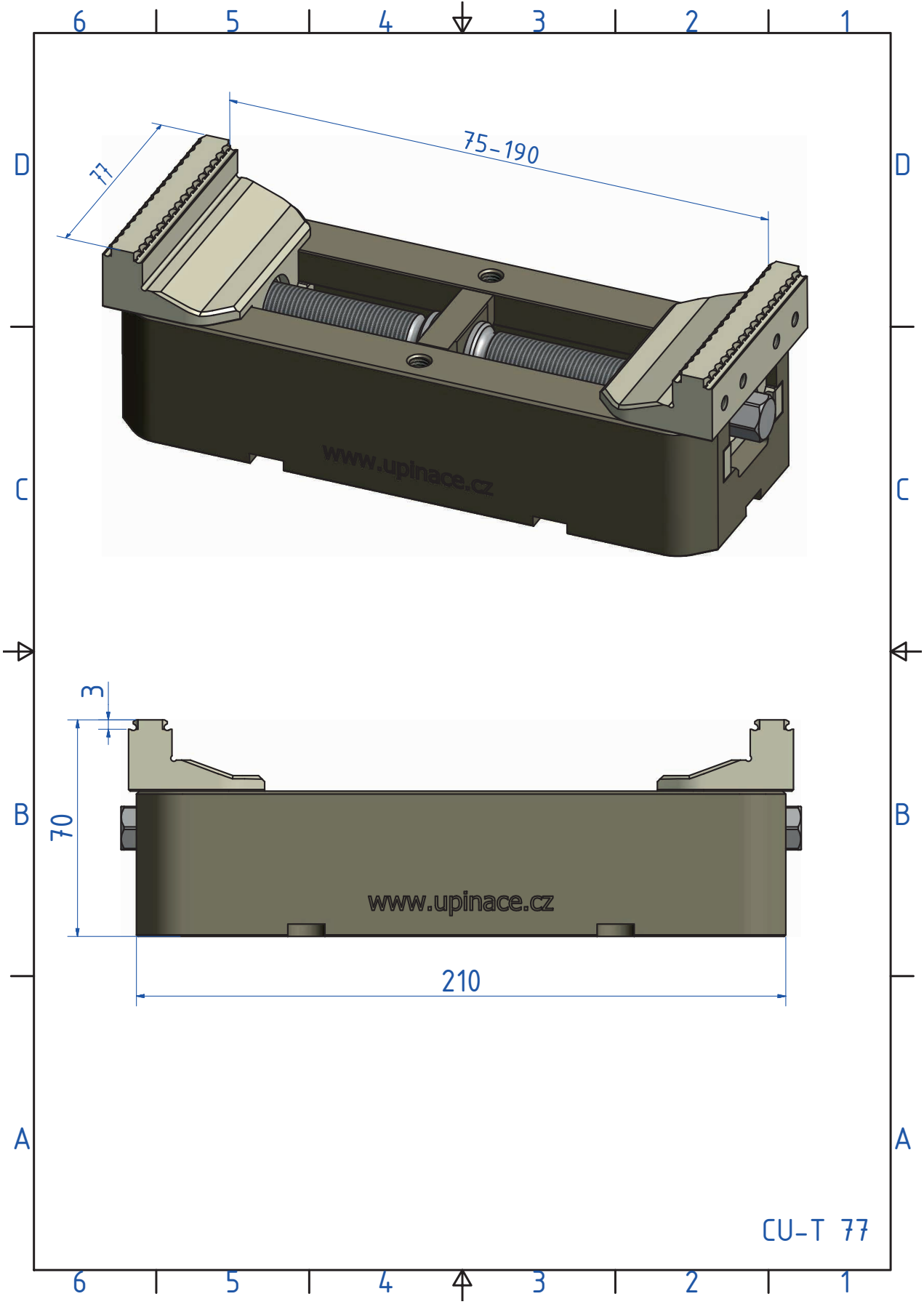

KASTR CU-T 77 LENGTH: 210

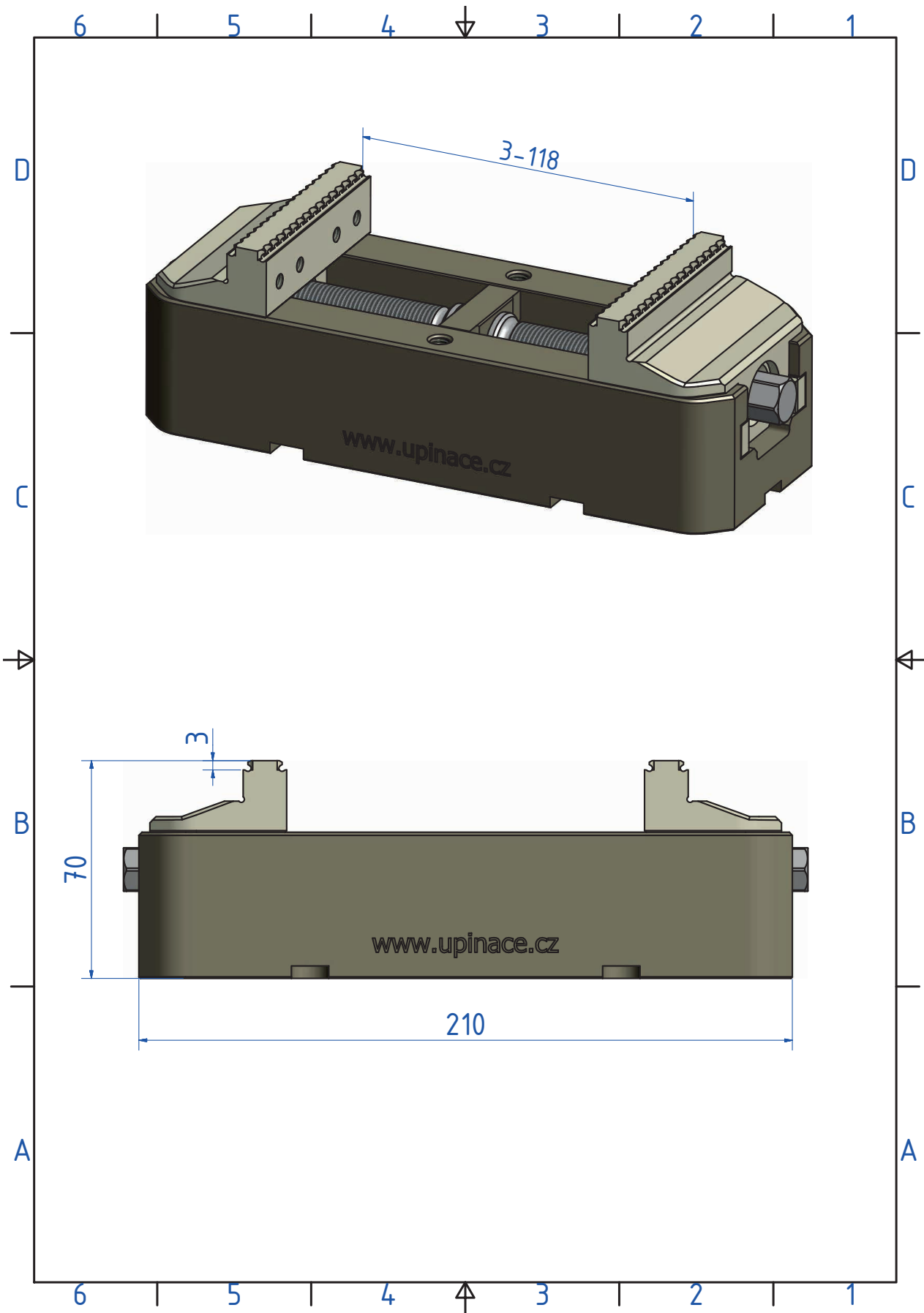

KASTR CU-T 77 LENGTH: 210 - WITH ROTATED SIDE JAWS

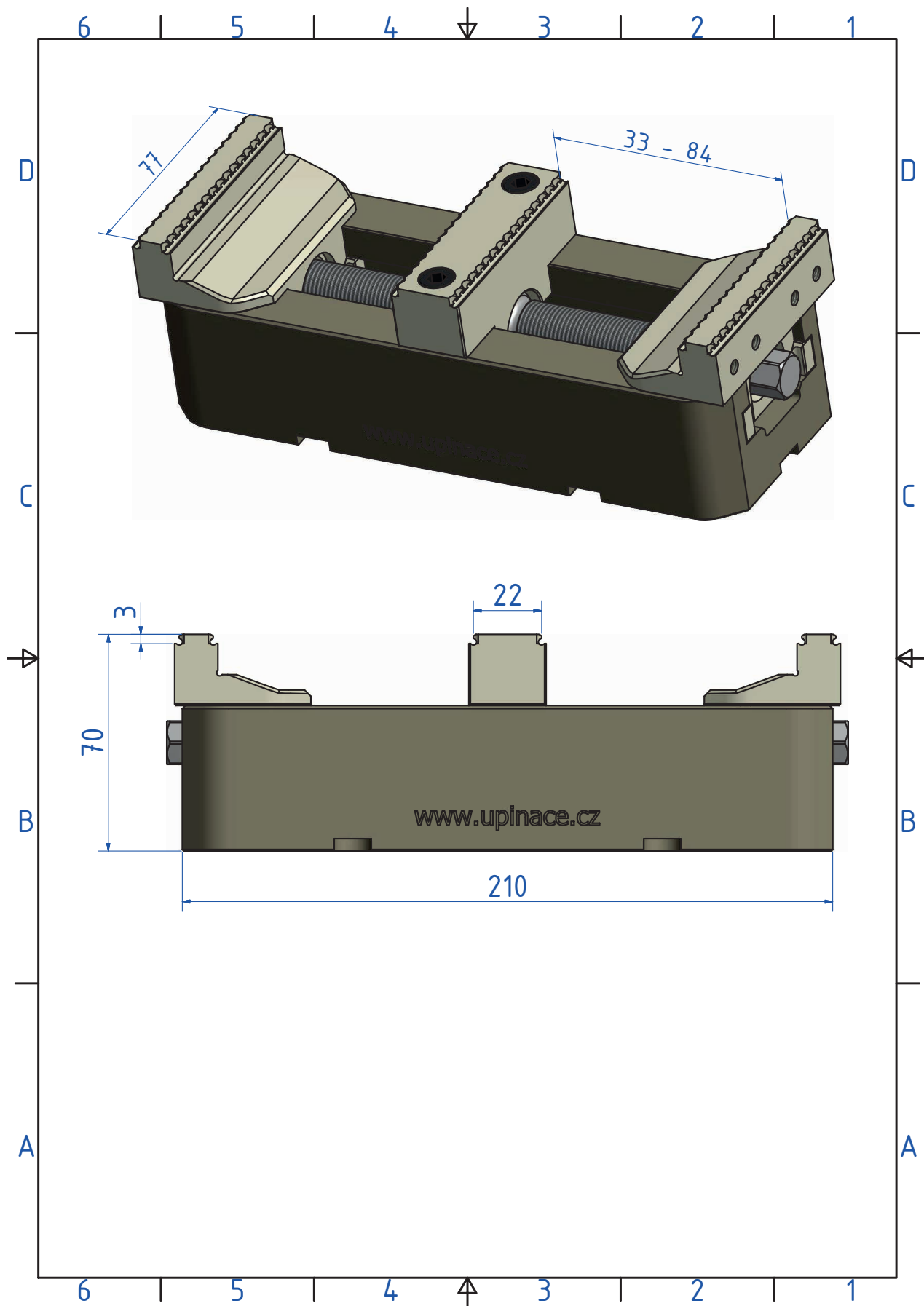

KASTR CU-T 77 LENGTH: 210 - WITH CENTAL JAW



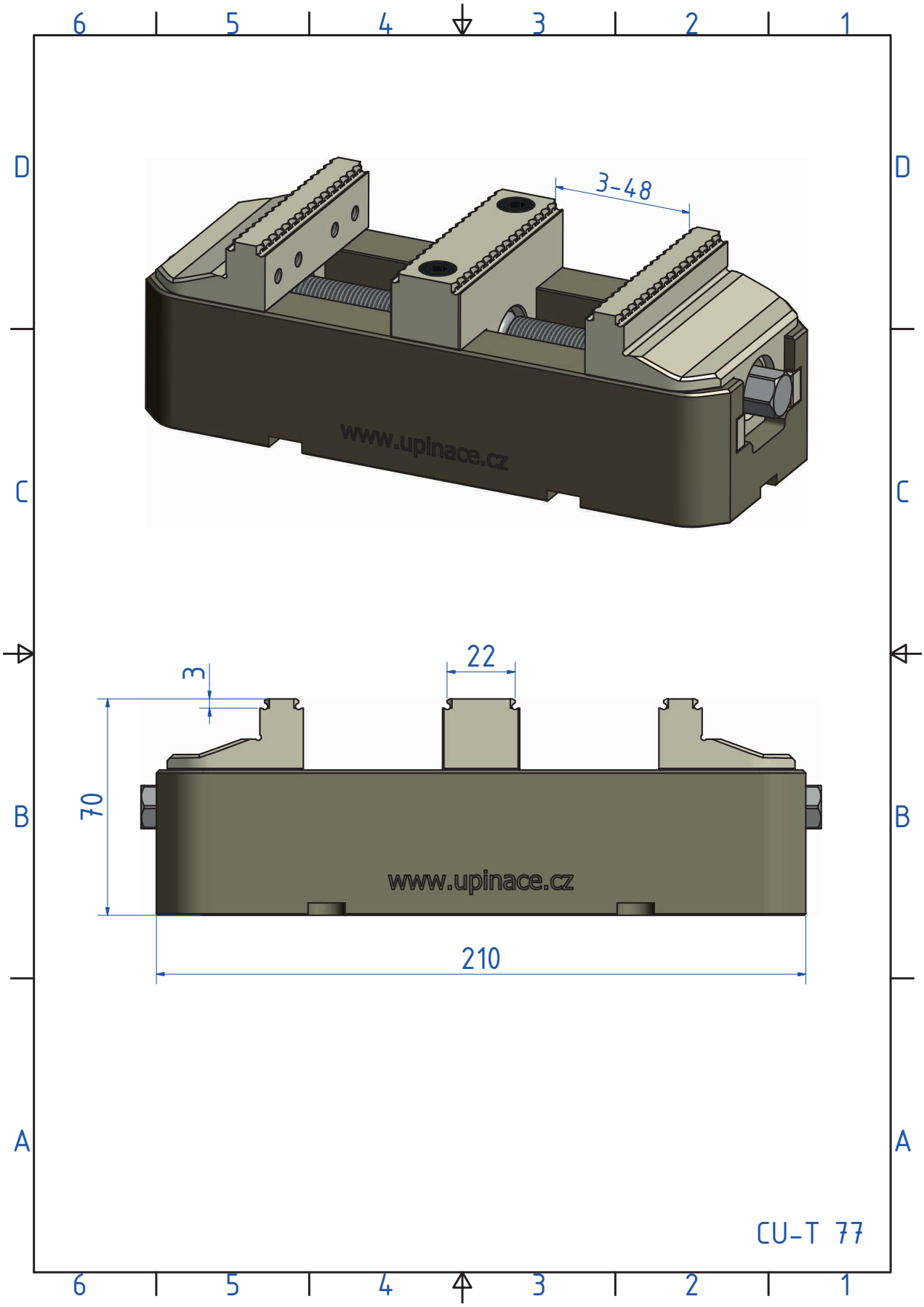

KASTR CU-T 77 LENGTH: 210 - WITH CENTRAL JAW AND ROTATED SIDE JAWS

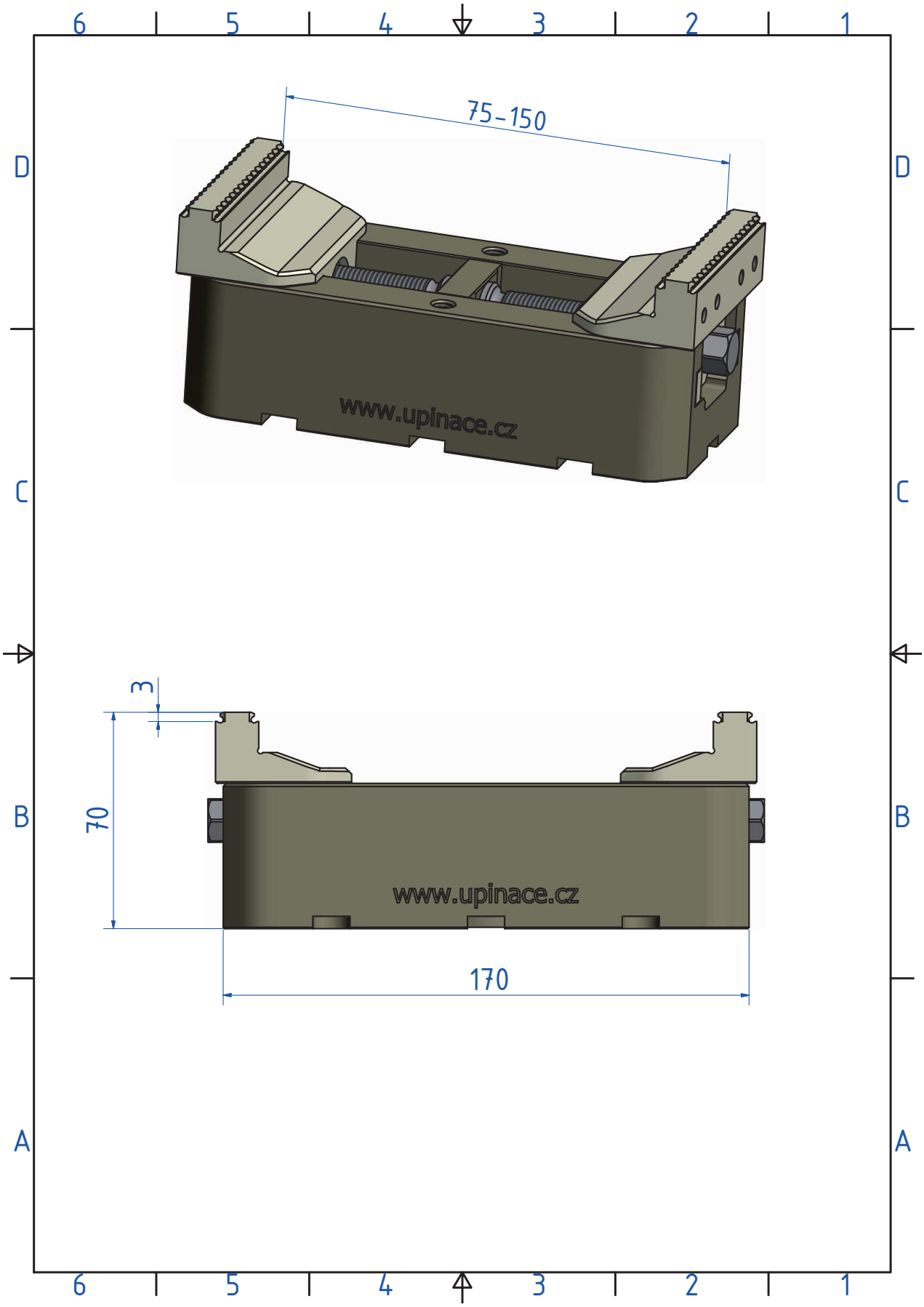

KASTR CU-T 77 LENGTH: 170



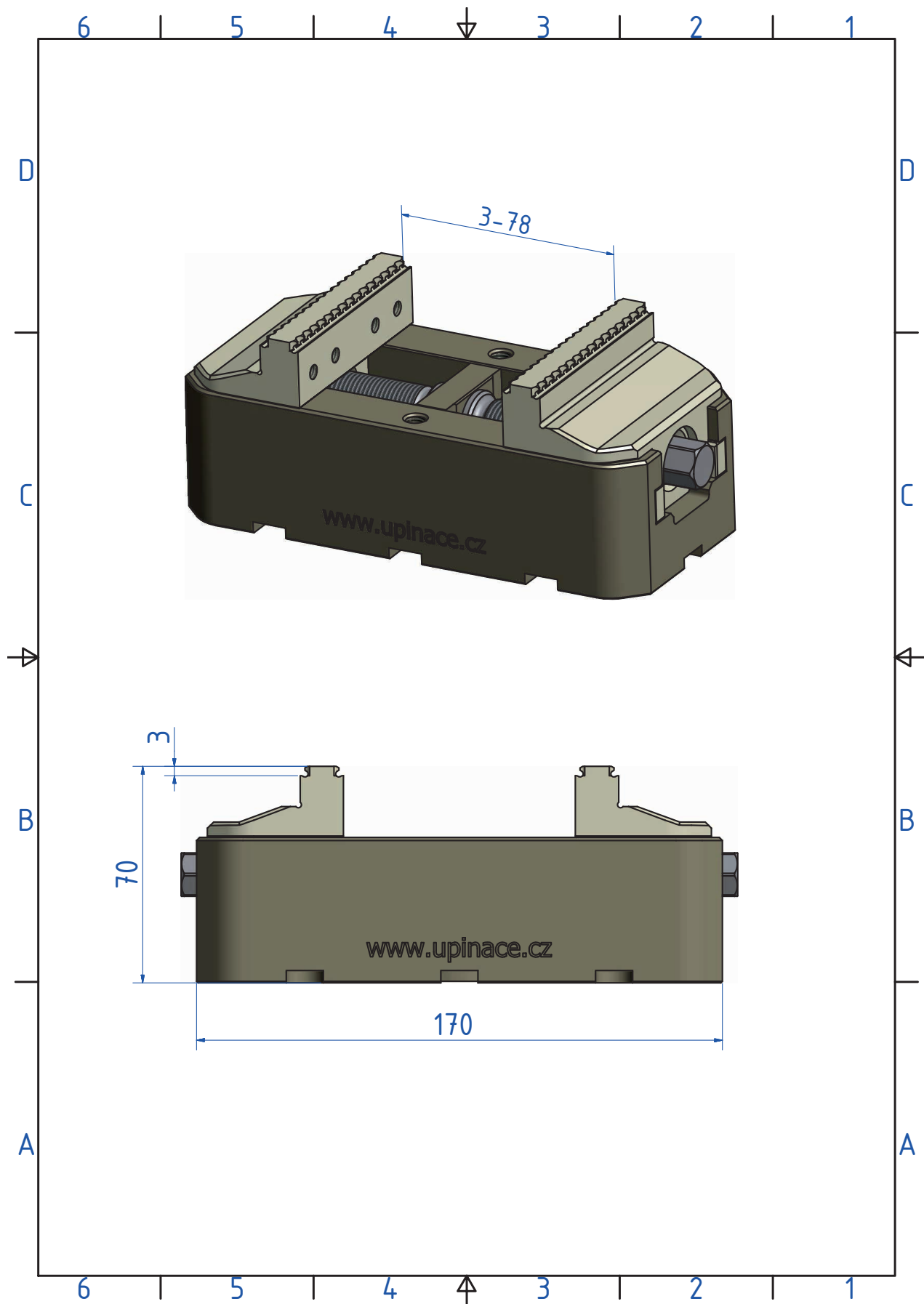

KASTR CU-T 77 LENGTH: 170 - WITH ROTATED SIDE JAWS

# Clamping on the turning table

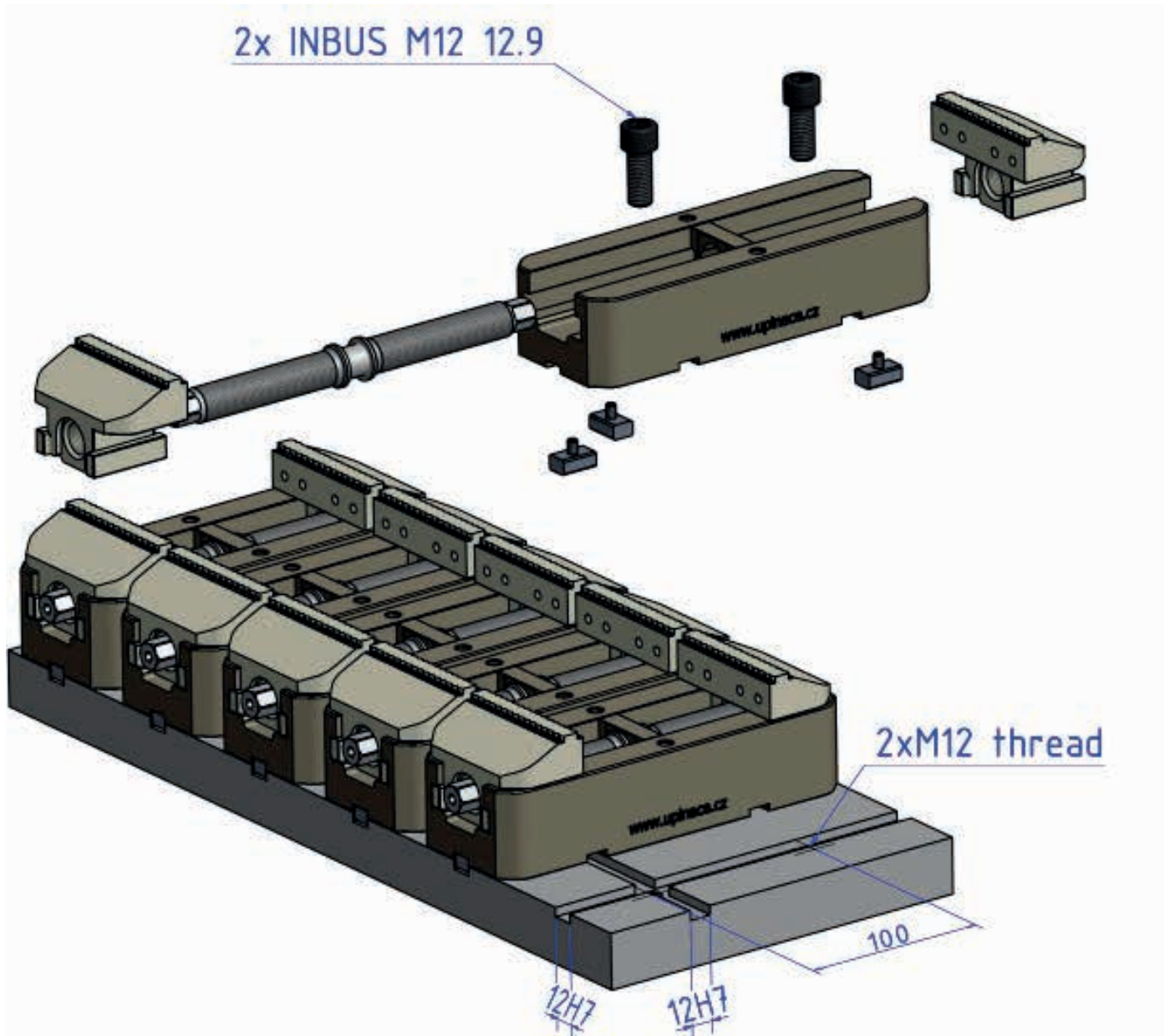

# Technical sheet KASTR CU-T 210

900.008TS1 Set for centric jaw

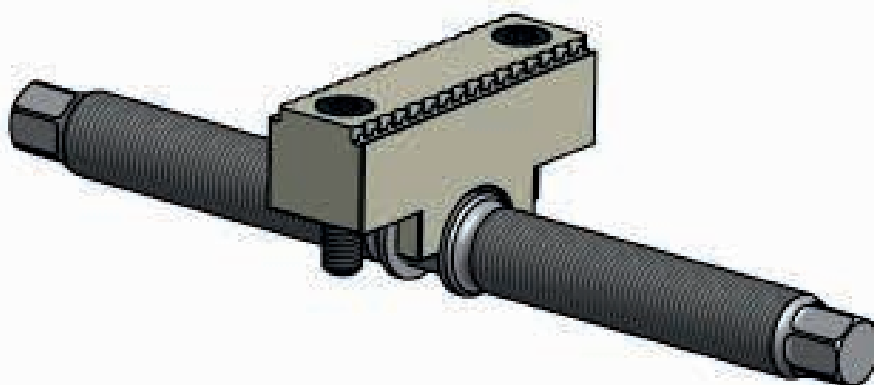

900.008T centric clamp KASTR CU-T 77 / 210

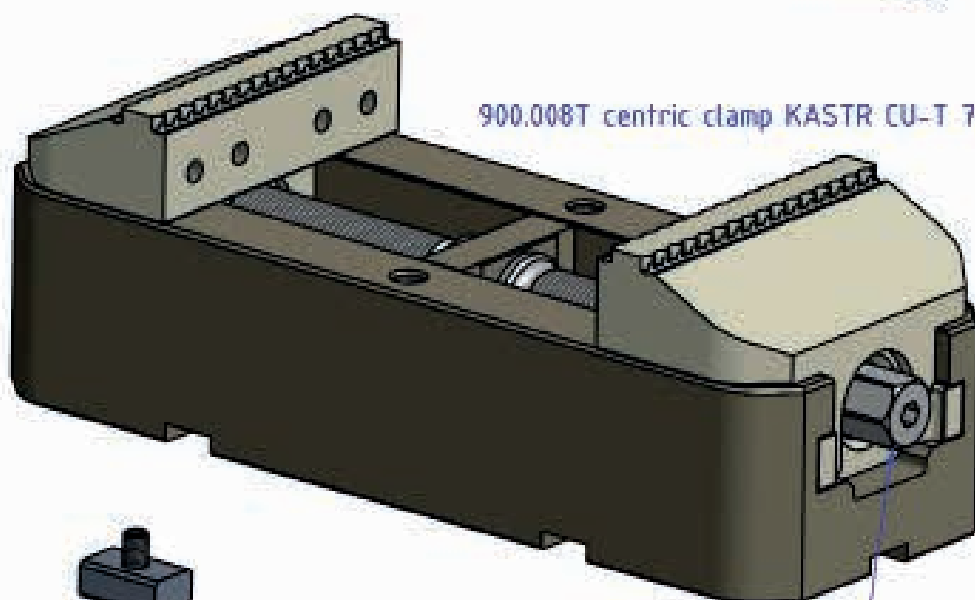

 14 - max. 200 Nm



900.008TM Mounting set  
(3x slot stone 12 mm, 3x M5x10, 2x M12x25)

# Technical sheet KASTR CU-T 170

900.008551 Set for centric jaw

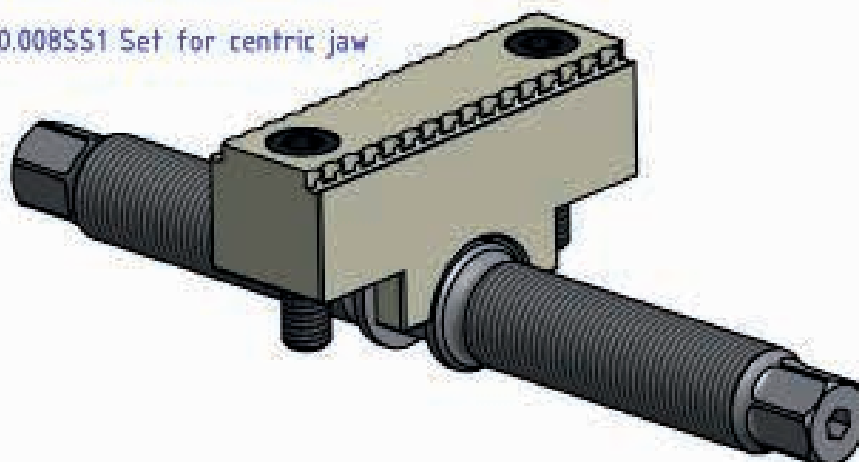

900.008S centric clamp KASTR CU-T 77 / 170

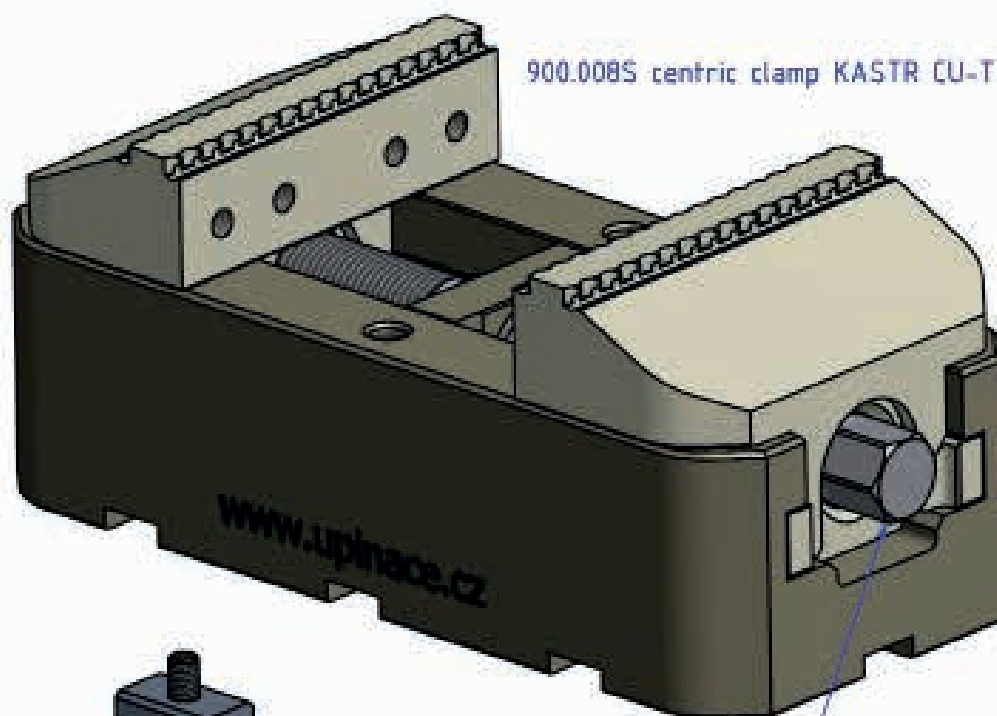

ST 14 - max. 200 Nm

900.008TM Mounting set  
(3x slot stone 12 mm, 3x M5x10, 2x M12x25)





**WEIGHT: 100 KG**  
**Material: Steel**  
**Size: 220 x 220 x 250**



**Manufactured on 1 clamping by 3 mm.**





# KASTR

CZECH FAMILY RUN BUSINESS

MILOSLAV KADERKA - KASTR  
ROZHRANÍ 172  
569 03 ROZHRANÍ  
CZECH REPUBLIC

[WWW.KASTR.CZ](http://WWW.KASTR.CZ)

email: [kaderka@kastr.cz](mailto:kaderka@kastr.cz)

tel: 00 420 461 523 457

